

KT08

CARTRIDGE SOLENOID VALVE SERIES 10



CARTRIDGE TYPE

seat 3/4-16 UNF-2B ISO 725

p max 350 bar

Q nom 50 l/min

OPERATING PRINCIPLE

- The KT08 is a 2-way solenoid valve, poppet type, cartridge execution, available in normally closed version (NC) and normally open version (NO) with nominal flow rate of 50 l/min.
- It ensures a low internal leakage, which decreases while the pressure increases.
- The valve can be ordered with direct current solenoids and with five types of electrical connections, in order to cover many installation requirements (see point 7).
- For every version, the manual override is an available option (see point 9).

PERFORMANCES

(working with mineral oil of viscosity of 36 cSt at 50°C)

Maximum operating pressure	bar	350
Nominal flow rate	l/min	50
Pressure drops $\Delta p - Q$		see point 3
Electrical characteristics		see point 5
Electrical connections		see point 7
Ambient temperature range	°C	-20 / +50
Fluid temperature range	°C	-20 / +80
Fluid viscosity range	cSt	10 + 400
Fluid contamination degree		According to ISO 4406:1999 class 20/18/15
Recommended viscosity	cSt	25
Mass	kg	0,32
Surface treatment with white colour zinc		According to ISO 2081 Fe/Zn12/A

HYDRAULIC SYMBOLS

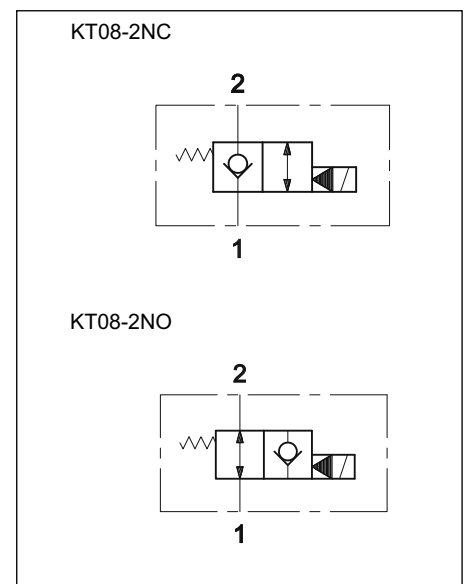



1 - IDENTIFICATION CODE

K	T	08	-		/	10	-			/	
----------	----------	-----------	----------	--	----------	-----------	----------	--	--	----------	--

Cartridge solenoid valve

Valve type
T = poppet type

Nominal dimension
08 = mounting interface 3/4-16 UNF-2B ISO 725

Spool types:
2NC = 2-way normally closed
2NO = 2-way normally open

Series no.:
(the overall and mounting dimensions remain unchanged from 10 to 19)

Seals:
N = NBR seals for mineral oil (**standard**)
V = FPM seals for special fluids

See **NOTE**

Coil electrical connection:
(see point 7)
K1 = plug for connector type EN 175301-803 (ex DIN 43650) (**standard**)

For **D12** and **D24** coils only:
K2 = plug for connector type AMP JUNIOR
K4 = outgoing cables
WK7 = plug DEUTSCH DT04-2P for male connector type DEUTSCH DT06-2S
WK8 = plug for connector type AMP SUPER SEAL

DC power supply:
D12 = 12 V
D24 = 24 V
D110 = 110 V
D220 = 220 V
D00 = Valve without coil (the coil locking ring and the relevant seals are included in the supply)

NOTE: The manual override **CM** is available as an option (see point 9).

1.1 - Coil identification code

C	14	L3	-		/	10
----------	-----------	-----------	----------	--	----------	-----------

DC power supply:
D12 = 12 V
D24 = 24 V
D110 = 110 V
D220 = 220 V

Series no.:
(the overall and mounting dimensions remain unchanged from 10 to 19)

Coil electrical connection (see point 7)
K1 = plug for connector type EN 175301-803 (ex DIN 43650) (**standard**)

For **D12** and **D24** coils only:
K2 = plug for connector type AMP JUNIOR
K4 = outgoing cables
WK7 = plug DEUTSCH DT04-2P for male connector type DEUTSCH DT06-2S
WK8 = plug for connector type AMP SUPER SEAL

2 - HYDRAULIC FLUIDS

Use mineral oil-based hydraulic fluids HL or HM type, according to ISO 6743-4. For these fluids, use NBR seals (code N). For fluids HFDR type (phosphate esters) use FPM seals (code V). For the use of other fluid types such as HFA, HFB, HFC, please consult our technical department. Using fluids at temperatures higher than 80 °C causes a faster degradation of the fluid and of the seals characteristics. The fluid must be preserved in its physical and chemical characteristics.

3 - PRESSURE DROPS Δp -Q

(obtained with viscosity of 36 cSt at 50 °C)

The values in graphs refer to both NC and NO valves and they differ for the mounting interface used.

standard mounting interface dimensions
3/4-16 UNF-2B ISO 725

dimensions in mm

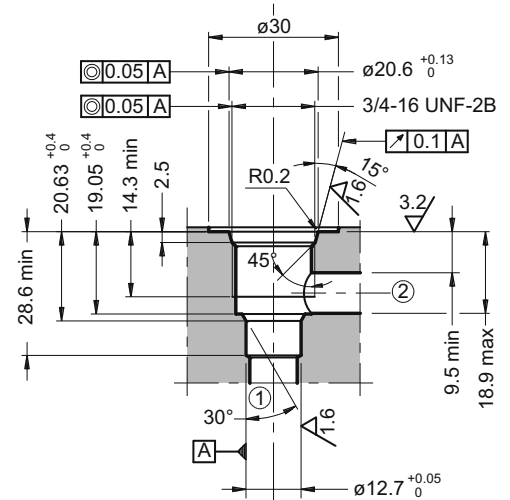
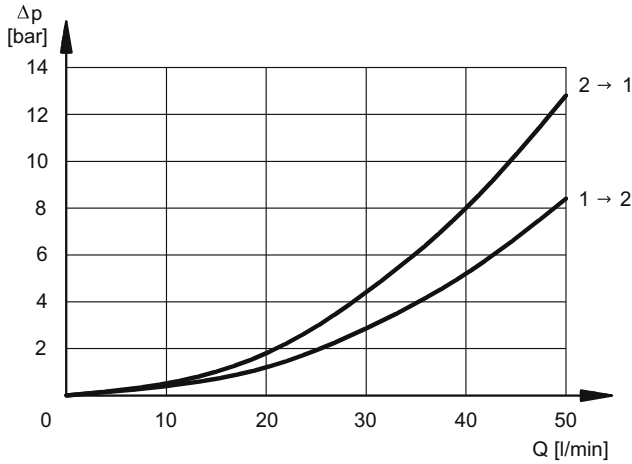

oversize mounting interface dimensions
3/4-16 UNF-2B ISO 725

dimensions in mm

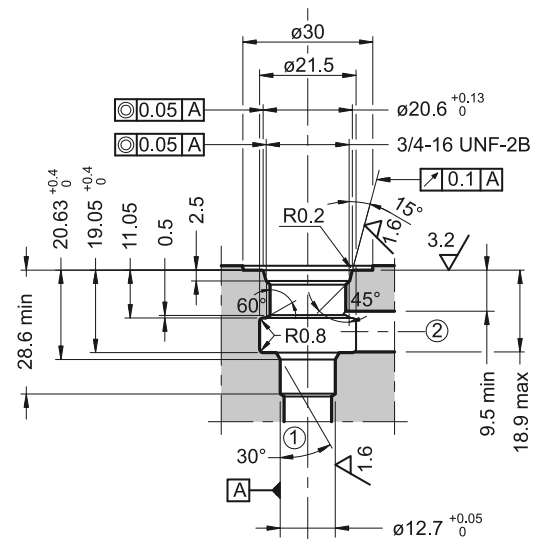
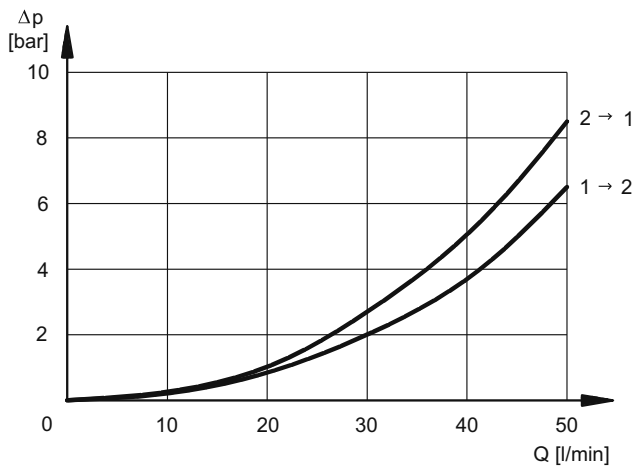

4 - SWITCHING TIMES

The values indicated refer to a valve tested with Q = 25 l/min, p = 350 bar, working with mineral oil at a temperature of 50°C and a viscosity of 36 cSt.

	TIMES (±10%)	
	ENERGIZING	DE-ENERGIZING
KT08-2NC	60 ms	85 ms
KT08-2NO	85 ms	60 ms

5 - ELECTRICAL FEATURES

5.1 - Solenoids

These are essentially made up of two parts: tube and coil. The tube is threaded onto the valve body and includes the armature that moves immersed in oil, without wear. The inner part, in contact with the oil in the return line, ensures heat dissipation. The coil is fastened to the tube by a threaded nut, and can be rotated according to the available space.

The interchangeability of coils of different voltages is possible without replace the tube.

Protection from atmospheric agents IEC 60529

The IP protection degree is intended for the whole valve. It is guaranteed only with both valve and connectors of an equivalent IP degree, correctly connected and installed.

Versions with CM manual override are IP65 always.

Electric connection	IP65	IP66	IP67	IP68	IP69 IP69K (*)
K1	x	x			
K2	x		x		
K4	x				
WK7	x		x	x	x
WK8	x	x	x	x	x

(*) The protection degree IP69K is not taken into account in IEC 60529 but it is included in both ISO 20653.

5.2 - Current and absorbed power for DC solenoid valve

The table shows current and power consumption values of the DC coils.

Using connectors type "D" (see cat. 49 000) with embedded bridge rectifier it is possible to feed DC coils (starting from 110V voltage) with alternating current (50 or 60 Hz), considering a reduction of the operating limits.

	Resistance at 20°C [Ω]	Current consumption [A]	Power consumption [W]	Coil code				
				K1	K2	K4	WK7	WK8
D12	5,4	2,20	26,5	1902740	1902750	1902770	1903510	1903520
D24	20,7	1,16	27,8	1902741	1902751	1902771	1903511	1903521
D110	424	0,26	28,5	1902746				
D220	1856	0,12	26,1	1902747				

6 - OVERALL AND MOUNTING DIMENSIONS

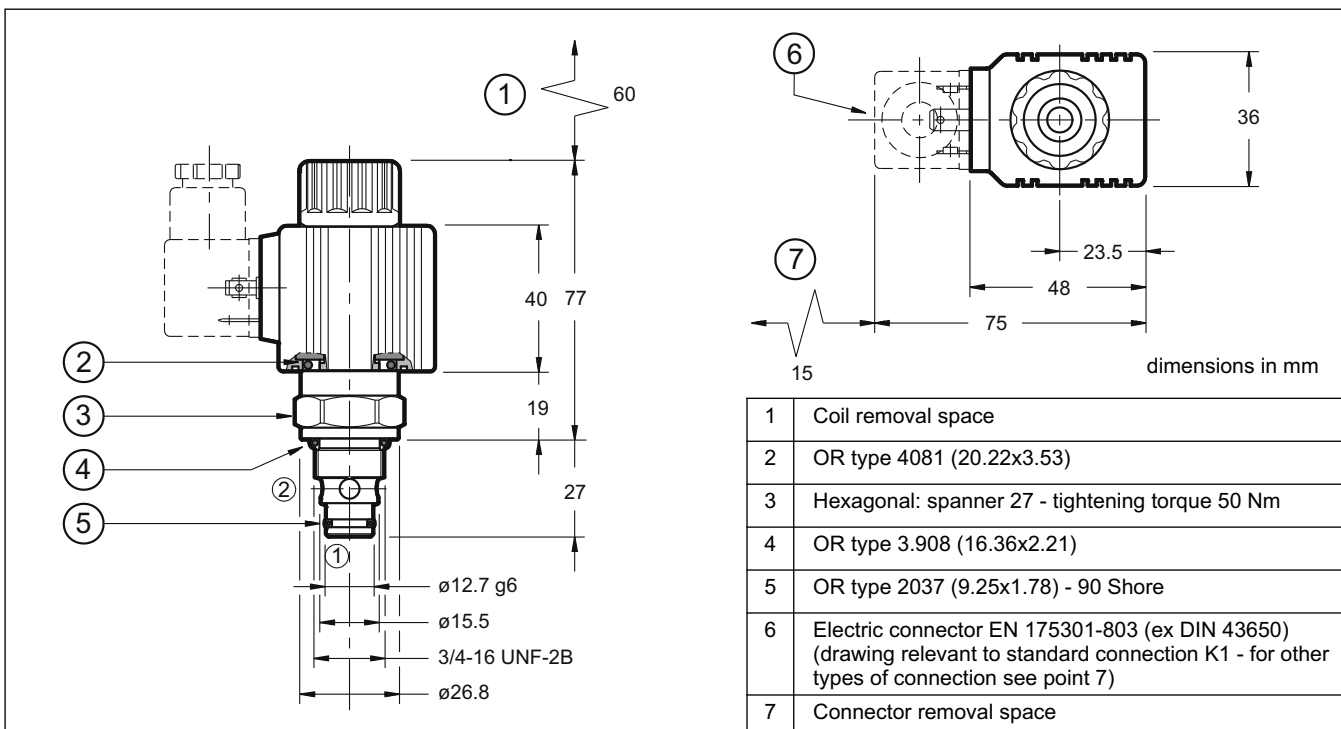

7 - ELECTRIC CONNECTIONS

connection for EN 175301-803
(ex DIN 43650) connector type
code **K1 (standard)**

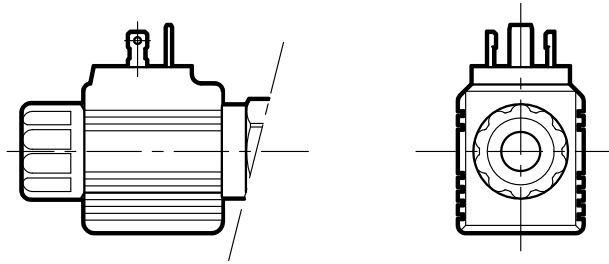

connection for AMP JUNIOR
connector type
code **K2**

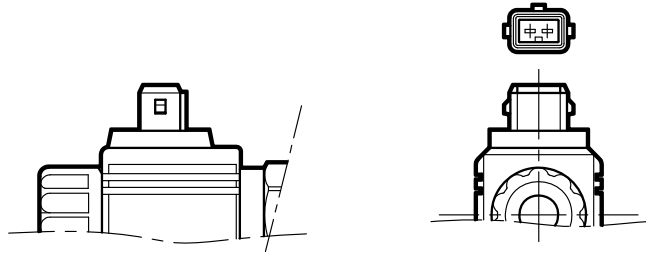

outgoing cable connections
cable length = 1 mt
code **K4**



connection for DEUTSCH DT04-2P
for male connector type DEUTSCH DT06
code **WK7**

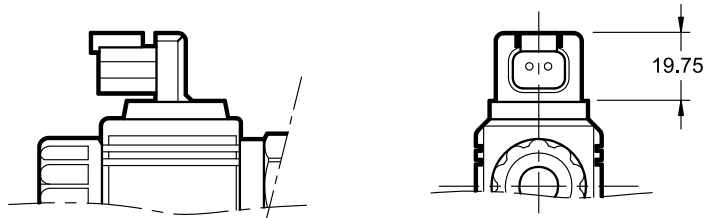

connection for AMP SUPER SEAL
(two contacts) connector type
code **WK8**

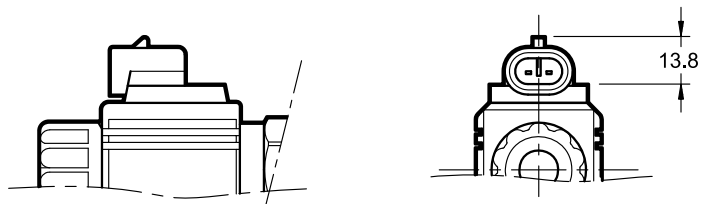

8 - ELECTRIC CONNECTORS

Solenoid valves are delivered without connectors. Connectors type EN 175301-803 (ex DIN 43650) for K1 connection can be ordered separately. See catalogue 49 000.

9 - MANUAL OVERRIDE

CM for NO version (pushing type)

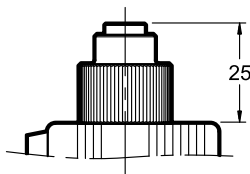

CM for NC version (screw type)

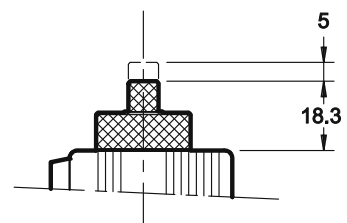

10 - SUBPLATES FOR MODULAR MOUNTING

10.1 - Identification code

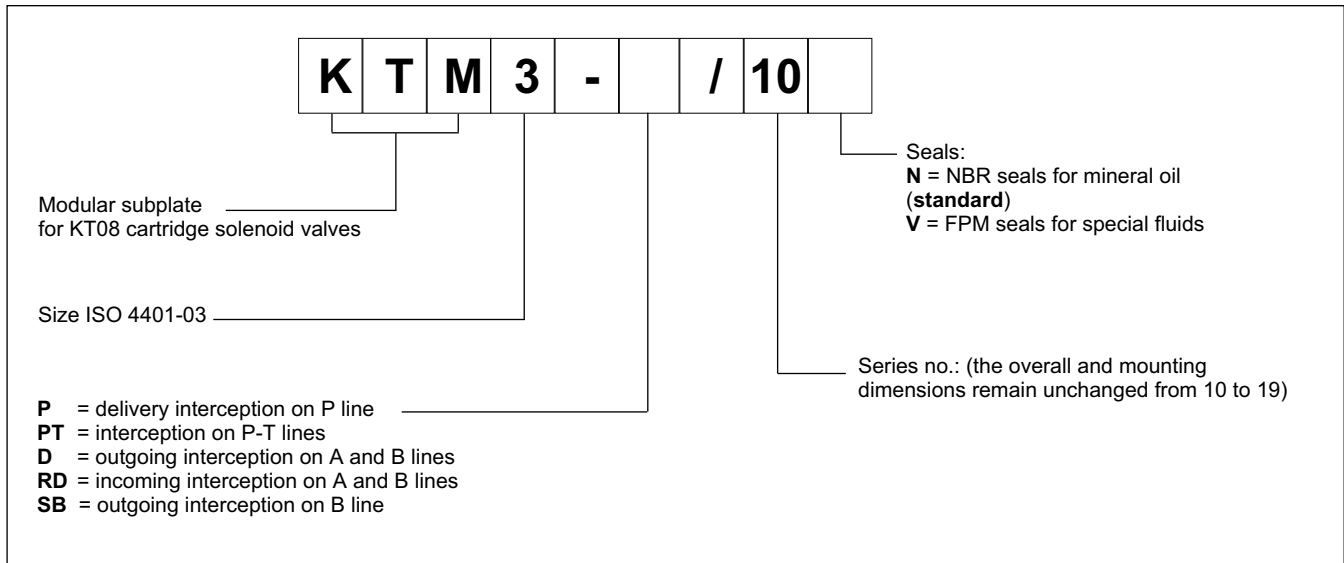

MOUNTING INTERFACE

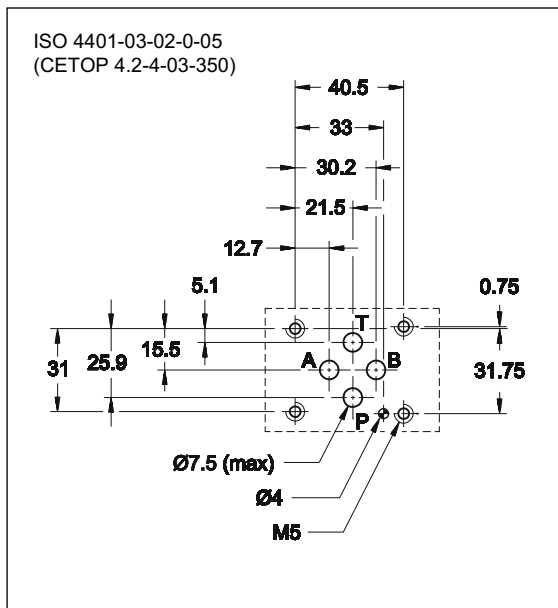

HYDRAULIC SYMBOLS

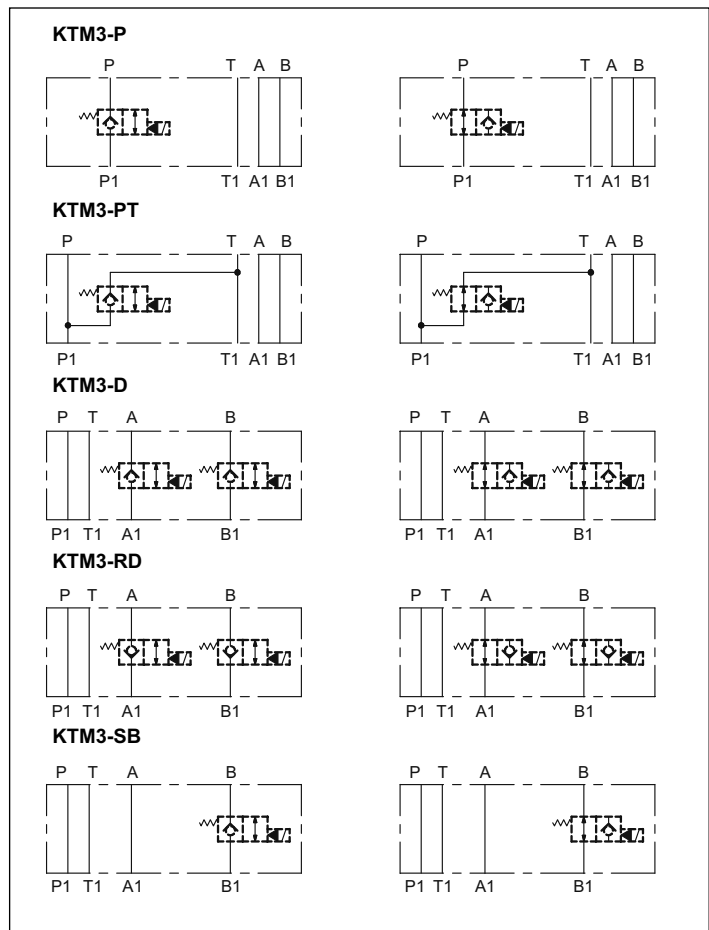

10.2 - Overall and mounting dimensions KTM3-P

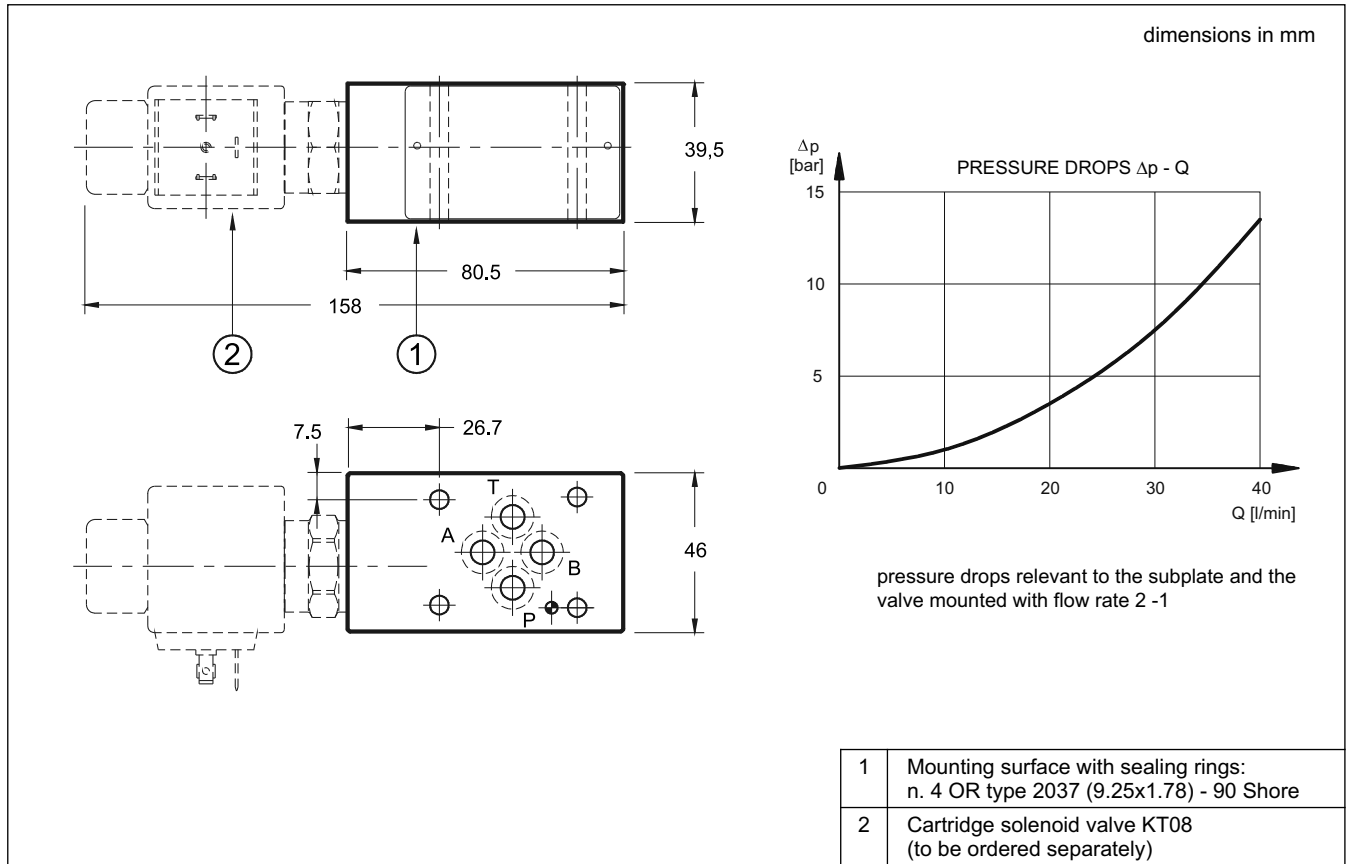

10.3 - Overall and mounting dimensions KTM3-PT

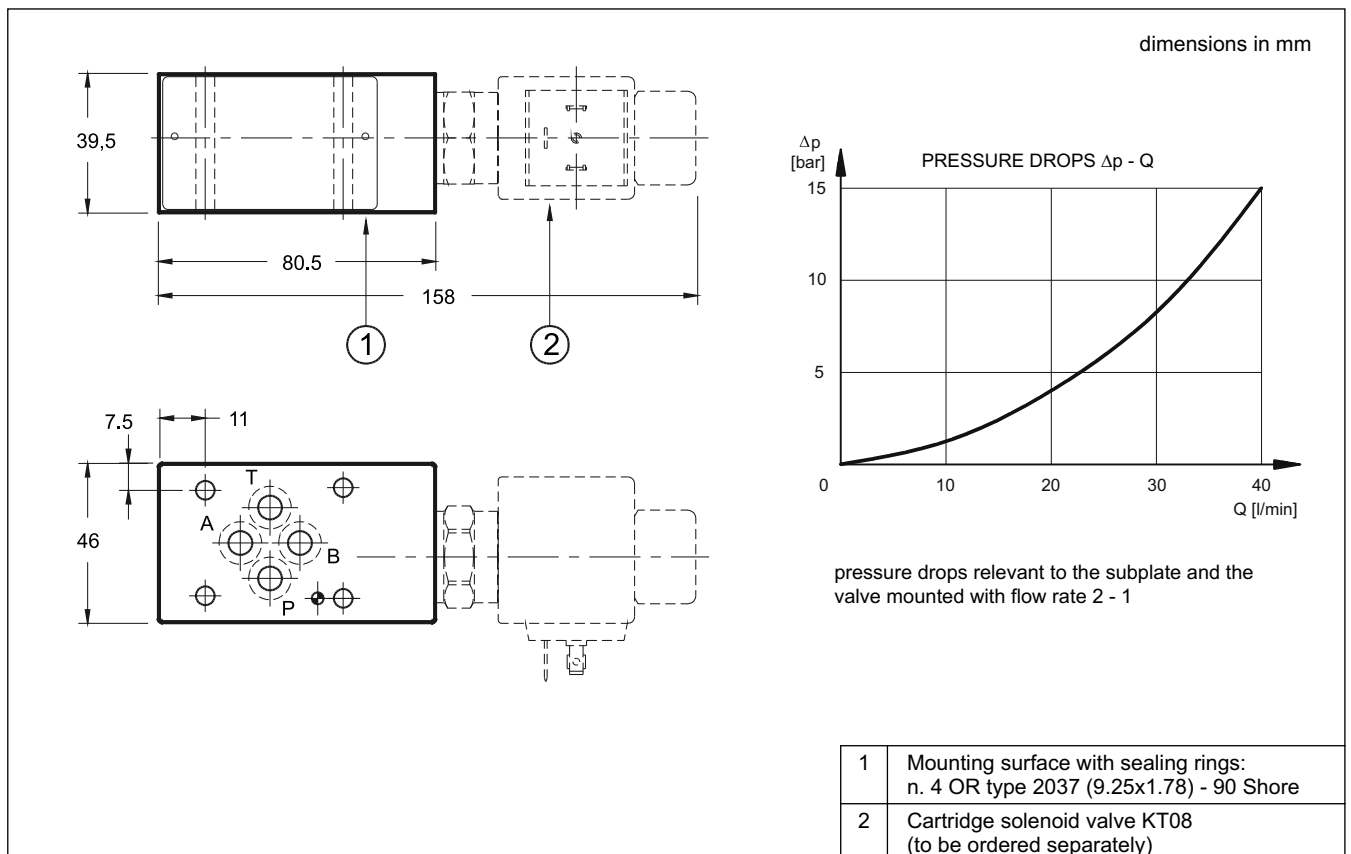

10.4 - Overall and mounting dimensions KTM3-D, KTM3-RD and KTM3-SB

KTM3-D
KTM3-RD

KTM3-SB

dimensions in mm

NOTE: In order to use a single port (shut-off of on path A), a plug must be ordered separately.
Code **0266683** for NBR seals (standard)
Code **0266684** for viton seals.

PRESSURE DROPS $\Delta p - Q$

(1) subplate pressure drops
(2) pressure drops relevant to the subplate and the valve mounted with flow rate 2 - 1

1	Mounting surface with sealing rings: n. 4 OR type 2037 (9.25x1.78) - 90 Shore
2	Cartridge solenoid valve KT08 (to be ordered separately)