



RQM*K-P

EXPLOSION-PROOF VERSION SOLENOID OPERATED PRESSURE RELIEF VALVES WITH UNLOADING AND PRESSURE SELECTION in compliance with ATEX 94/9/CE

SERIES 21

SUBPLATE MOUNTING

RQM3K-P ISO 6264-06 (CETOP R06)

RQM5K-P ISO 6264-08 (CETOP R08)

RQM7K-P ISO 6264-10 (CETOP R10)

OPERATING PRINCIPLE

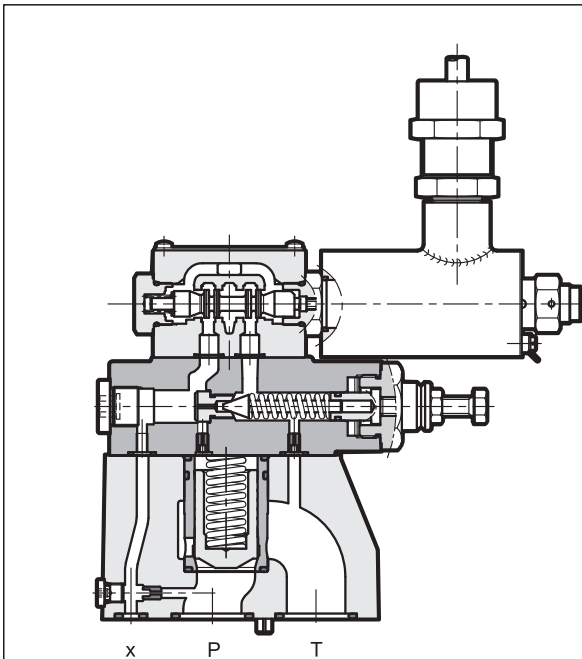

- The RQM*K-P valves are explosion-proof pressure relief valves, available in in ISO 6264 (CETOP RP 121H) subplate mounting version with three nominal sizes for flow up to 500 l/min.
- The RQM*K-P valves are ATEX 94/9/CE standards certified and are suitable for the use in potentially explosive atmospheres, that fall within either the ATEX II 2GD for gas or for dust classification. See par. 5.2 for electrical characteristics.
- They are available in five versions that allow the unloading of the total flow and selection up to three pressure values (see table 2 Versions) by means of a solenoid valve.
- They are supplied with a hexagonal head adjustment screw. Upon request, it can be equipped with a SICBLOC adjustment knob on the main pressure control.
- The adjustment of the second and third pressure values is obtained by a pressure relief valve placed between the main stage and the solenoid valve.
- The declaration of conformity to the upmentioned standards is always supplied with the valve.

TYPE EXAMINATION CERTIFICATE NUMBER: CEC 10/2003 - AET 619

PERFORMANCES (measured with mineral oil of viscosity 36 cSt at 50°C)

		RQM3K-P	RQM5K-P	RQM7K-P
Maximum operating pressure	bar	350		
Maximum flow rate	l/min	200	400	500
Ambient temperature range	°C	-20 / +40		
Fluid temperature range	°C	-20 / +60		
Fluid viscosity range	cSt	10 + 400		
Fluid contamination degree		According to ISO 4406:1999 class 20/18/15		
Recommended viscosity	cSt	25		

1 - IDENTIFICATION CODE

	R	Q	M	K	-	P	/	/	/	21	-	K5
--	----------	----------	----------	----------	----------	----------	----------	----------	----------	-----------	----------	-----------

pilot operated pressure relief valve

solenoid valve for unloading / pressure selection

Size:
3 = ISO 6264-06 (CETOP R06)
5 = ISO 6264-08 (CETOP R08)
7 = ISO 6264-10 (CETOP R10)

K = Explosion-proof version according to ATEX - II 2GD for gas or for dust

Subplate mounting

Pressure adjustment range:
3 = up to 70 bar **5** = up to 210 bar **6** = up to 350 bar

Versions: **A**
B
C
D
G } see description in the table 2 - version

Coil with outgoing cables and cable clamp

Coil type:
direct current supply
D12 = 12 V
D24 = 24 V
D110 = 110 V
alternating current supply (coil with built-in rectifier bridge)
AR24 = 24 V
AR110 = 110 V
AR230 = 230 V

Seals:
N = NBR seals for mineral oil (standard)
V = FPM seals for special fluids

Series No. (the overall and mounting dimensions remain unchanged from 20 to 29)

M = adjustment with SICBLOC knob available only on the main pressure control (Omit for adjustment with hexagonal head screw)

2 - VERSIONS

RQM*K-P*/A	RQM*K-P*/B	RQM*K-P*/C	RQM*K-P*/D	RQM*K-P*/G
<p>1 pressure setting and unloading with de-energized solenoid</p>	<p>1 pressure setting and unloading with energized solenoid</p>	<p>2 pressure settings The highest setting is reached with energized solenoid</p>	<p>2 pressure settings and unloading with de-energized solenoids</p>	<p>3 pressure settings The highest setting is reached with de-energized solenoids</p>

3 - CHARACTERISTIC CURVES (values obtained with viscosity of 36 cSt at 50°C)

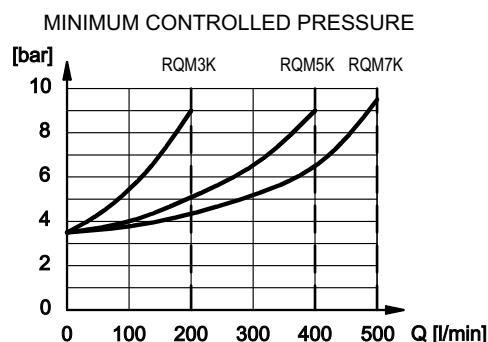
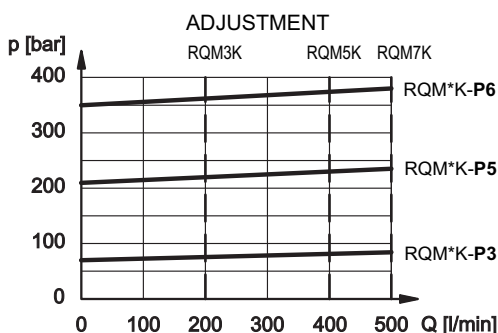



4 - HYDRAULIC FLUIDS

Use mineral oil-based hydraulic fluids HL or HM type, according to ISO 6743-4. For these fluids, use NBR seals (code N). For fluids HFDR type (phosphate esters) use FPM seals (code V). For the use of other kinds of fluid such as HFA, HFB, HFC, please consult our technical department. Using fluids at temperatures higher than 80 °C causes a faster degradation of the fluid and of the seals characteristics.

The fluid must be preserved in its physical and chemical characteristics.

5 - ELECTRICAL CHARACTERISTICS

5.1 Classification

The valves can be used for applications and installations in potentially explosive atmospheres that fall within either the ATEX II 2G or the ATEX II 2D classification.

- Group: II (surface plants)
- Category: 2 (high protection for areas 1 and 2)
- Type of atmosphere: G (explosive atmosphere with gas or vapours)
D (explosive atmosphere with dust)

5.2 Solenoids

These are essentially made up of two parts: tube and coil. The tube is threaded onto the valve body and includes the armature that moves immersed in oil, without wear. The inner part, in contact with the oil in the return line, ensures heat dissipation.

The coil is fastened to the tube by an hexagonal threaded nut provided with anti-unlocking safety screw and it can be turned 360° on its axis, depending on the available space.

The mechanical construction of the coil housing is made in order to ensure its resistance to possible internal explosion and to avoid any explosion propagation to the outside environment.

Moreover, the solenoid is designed to maintain its surface temperature below the limits specified to the relevant class.

The AR coils (for alternating current supply) contain a built-in rectifier bridge.

VOLTAGE SUPPLY FLUCTUATION	± 10% Vnom
MAX SWITCH ON FREQUENCY	8.000 ins/hr
DUTY CYCLE	100%
EXPLOSION-PROOF VERSION	According to ATEX 94/9/CE
ELECTROMAGNETIC COMPATIBILITY (EMC)	According to 2004/108/CE
LOW VOLTAGE	According to 2006/95/CE
TEMPERATURE CLASS	T5 (surface temperature ≤ 100°C)
CLASS OF PROTECTION: Atmospheric agents (CEI EN 60529) Coil insulation	IP 67 class H

5.3 Current and power consumption

The table shows current and power consumption values relevant to the different coil types, for direct or alternating 50 or 60 Hz current supply.

AR coils must be used when the valve is fed with AC power supply and then rectified by means of the rectifier bridge incorporated into the coil.

Coil Type	Absorbed current A (± 5%)	Power (± 5%)	
		W	VA
D12	0,92	11	
D24	0,46	11	
D110	0,10	11	
AR24	0,46		11
AR110	0,1		11
AR230	0,05		11

NOTE: AR coils are AC power regardless of whether 50 or 60 Hz.

6 - OVERALL AND MOUNTING DIMENSIONS

dimensions in mm

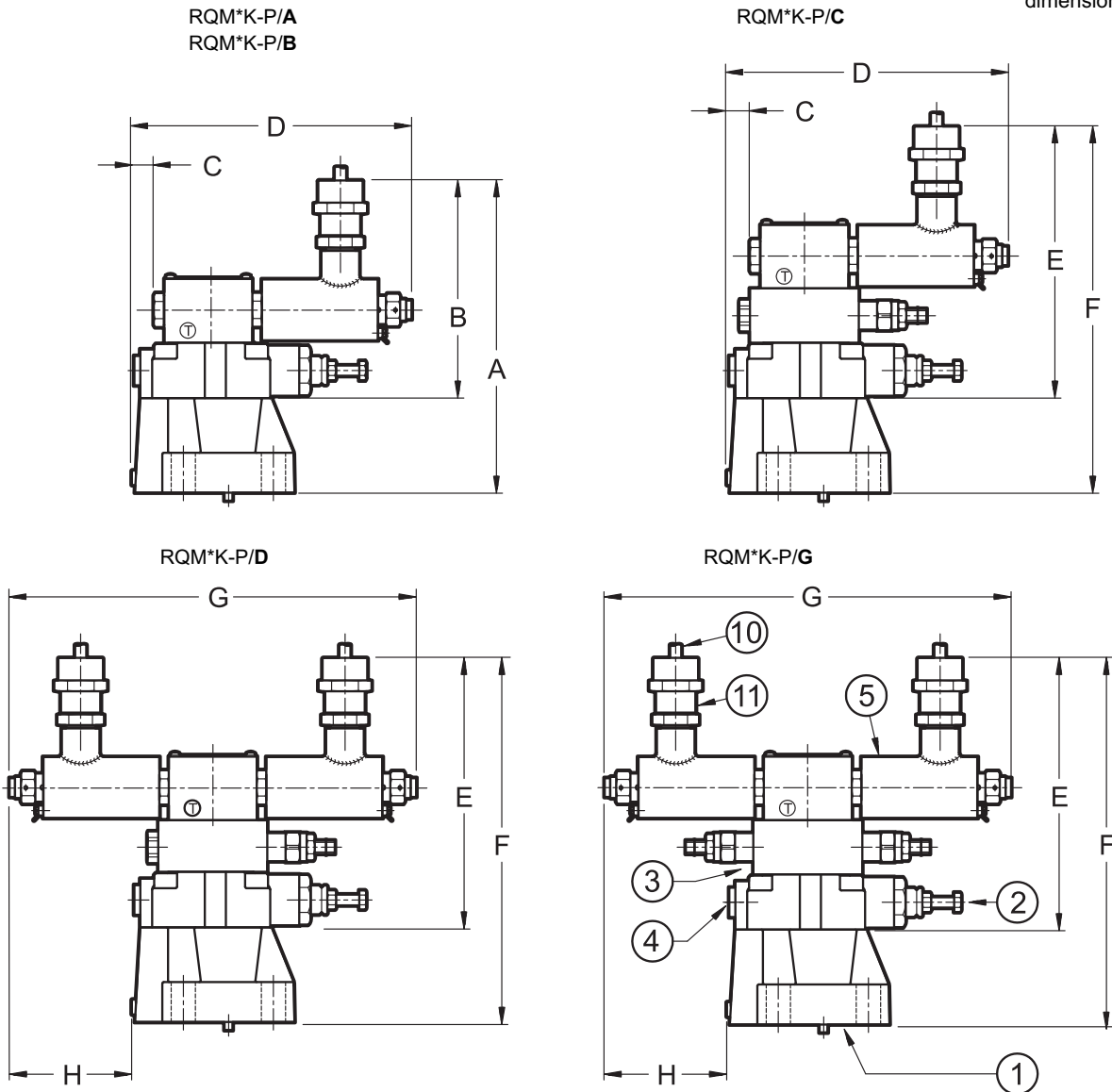

1	Mounting surface For fastening bolts and sealing rings see paragraph 9
2	Hexagonal head main pressure adjustment screw: Spanner 13 Clockwise rotation to increase pressure
3	Second value pressure adjustment valve. Countersunk hex adjustment screw: Spanner 5 Clockwise rotation to increase pressure
4	Pressure gauge port 3/8" BSP
5	ISO 4401-03 (CETOP 03) solenoid valve for pressure selection / unloading with explosion-proof coils

6	Hexagonal nut for coil fastening: spanner 24
7	Anti-unlocking safety screw: spanner 1,5
8	Manual override
9	Terminal for supplementary earth connection
10	Fire-proof power cable CEI 20-22: L = 1500 mm External diameter = Ø 8 mm Wires no. = 3 (2 poles + earth) Wires section= 1,5 mm ²
11	Cable clamp

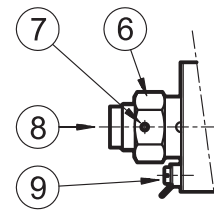

	A	B	C	D	E	F	G	H
RQM3K	222	162	25	216	200	262	300	88
RQM5K	232	162	16	207	200	272	300	96
RQM7K	242	162	27	218	200	282	300	85

7 - MOUNTING INTERFACES

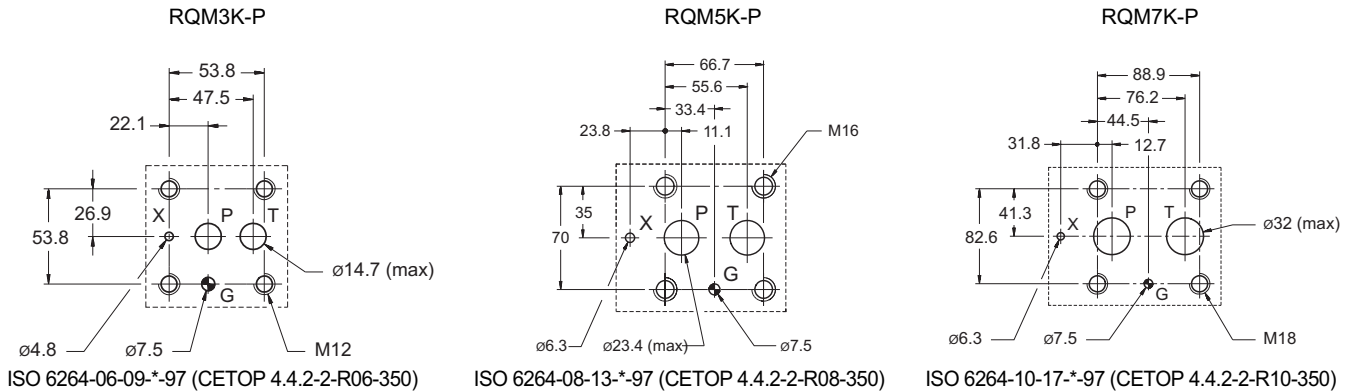

8 - ADJUSTMENT KNOB

The RQ valves can be equipped with a SICBLOC adjustment knob, only on the main pressure regulation.

To operate it, push and rotate at the same time. To request this option, add: /M (see paragraph 1).

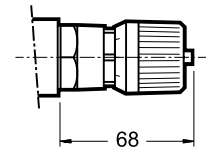

9 - FASTENING BOLTS AND SEALING RINGS

	RQM3K-P	RQM5K-P	RQM7K-P
Fastening (4 bolts)	M12 x 40	M16 x 50	M18 x 60
Torque	69 Nm	170Nm	235Nm
Sealing rings	N. 2 OR type 123 (17.86x2.62) 90 Shore N. 1 OR type 109 (9.13x2.62) 90 Shore	N. 2 OR type 3118 (29.82x2.62) 90 Shore N. 1 OR type 109 (9.13x2.62) 90 Shore	N. 2 OR type 4137 (34.52x3.53) 90 Shore N. 1 OR type 109 (9.13x2.62) 90 Shore

10 - SUBPLATES (see catalogue 51 000)

	RQM3K-P	RQM5K-P	RQM7K-P
Type	PMRQ3-AI4G rear ports	PMRQ5-AI5G rear ports	PMRQ7-AI7G rear ports
Port dimensions PT	1/2" BSP	1" BSP	1 1/4" BSP
Port dimension X	1/4" BSP	1/4" BSP	1/4" BSP



RQM*K-P

SERIES 21



DIPLOMATIC OLEODINAMICA S.p.A.
20015 PARABIAGO (MI) • Via M. Re Depaolini 24
Tel. +39 0331.895.111
Fax +39 0331.895.339
www.diplomatic.com • e-mail: sales.exp@diplomatic.com

